

【性能表】 Performance Data

吸入風量: Q(m³/min) 軸動力: L(kW)

型式 TYPE	回転速度 min-1	10 kPa		20 kPa		30 kPa		40 kPa		50 kPa		60 kPa	
		Q	L	Q	L	Q	L	Q	L	Q	L	Q	L
IRS-150AS	700	10.6	3.55	9.31	5.98	8.28	8.41	7.42	10.8	6.65	13.2	5.96	15.7
	1000	16.6	5.07	15.2	8.54	14.2	12.0	13.3	15.4	12.6	18.9	11.9	22.4
	1300	22.5	6.59	21.2	11.1	20.1	15.6	19.3	20.1	18.5	24.6	17.8	29.1
	1600	28.5	8.11	27.1	13.6	26.1	19.2	25.2	24.7	24.5	30.3	23.8	35.8
	1800	32.4	9.13	31.1	15.3	30.1	21.6	29.2	27.8	28.4	34.1	27.8	40.3
IRS-200AS	700	15.0	4.78	13.1	8.17	11.7	11.5	10.5	14.9	9.53	18.3	8.59	21.7
	1000	23.3	6.83	21.5	11.6	20.1	16.5	18.9	21.3	17.8	26.1	16.9	31.0
	1300	31.6	8.88	29.8	15.1	28.4	21.4	27.2	27.7	26.2	34.0	25.2	40.3
	1600	40.0	10.9	38.1	18.6	36.7	26.4	35.5	34.1	34.5	41.8	33.6	49.6
	1800	45.5	12.3	43.7	21.0	42.3	29.7	41.1	38.4	40.1	47.1	39.1	55.8
IRS-200CS	600	27.7	8.24	25.0	14.1	22.9	20.0	21.1	25.9	19.5	31.8	18.1	37.7
	800	39.2	10.9	36.4	18.8	34.3	26.7	32.5	34.5	31.6	42.4	29.5	50.3
	1000	50.7	13.7	47.9	23.5	45.8	33.3	44.0	43.2	42.5	53.0	41.0	62.8
	1200	62.2	16.4	59.4	28.2	57.3	40.0	55.5	51.8	53.9	63.6	52.5	75.4
	1300	67.9	17.8	65.1	30.6	63.0	43.4	61.2	56.1	59.7	68.9	58.2	81.7
IRS-250AS	600	39.8	11.7	35.9	20.1	33.0	28.6	30.5	37.0	28.3	45.4	26.3	53.8
	800	56.2	15.7	52.3	26.9	49.4	38.1	46.9	49.3	44.7	60.5	42.7	71.7
	1000	72.6	19.6	68.7	33.6	65.8	47.6	63.3	61.6	61.1	75.7	59.1	89.7
	1200	89.0	23.5	85.1	40.3	82.2	57.1	79.7	74.0	77.5	90.8	75.5	107
	1300	97.2	25.5	93.3	43.7	90.4	61.9	87.9	80.1	85.7	98.4	83.7	116

注1 上記仕様範囲を超えるものは別途お問い合わせ下さい。

注2 モータ出力の設定は原則として軸動力の10~20%増として下さい。

注3 上記吸入風量、軸動力は吸入・吐出サイレンサ等の圧力損失及び動力伝達損失は含んでおりません。

*1 In case of exceeding range described above, please contact us.

*2 In principle, Motor output should be 1.1-1.2 times of shaft power.

*3 Suction Capacity (Q) and Shaft Power (L) on Performance Data do not include any Pressure Drops of Suction and Discharge side (ex. Silencer) and Power Transmission Loss.

【据付外形図】

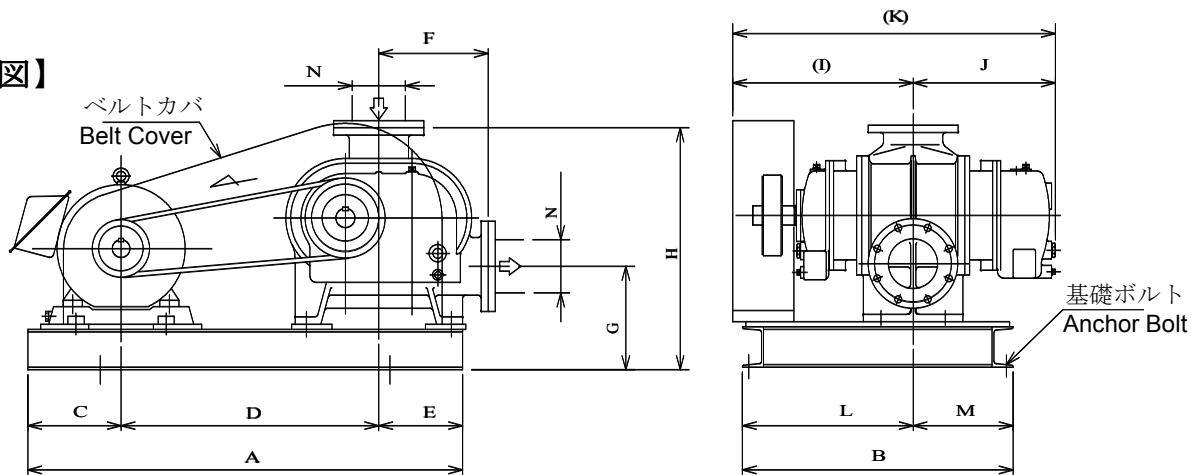

【寸法表】

型式 Type	A	B	C	D	E	F	G	H	I	J	K	L	M	N	質量 Mass
IRS-150AS	1350	840	290	800	260	340	321	751	560	442	1002	530	310	150A	690 kg
IRS-200AS	1350	840	290	800	260	340	341	751	620	502	1122	510	330	200A	770 kg
IRS-200CS	1600	900	350	920	330	450	392	1012	645	544	1189	580	320	200A	1300 kg
IRS-250AS	1700	1200	430	940	330	450	392	1012	735	634	1369	700	500	250A	1600 kg

注1 モータサイズにより基礎寸法が異なる場合があります。

注2 フランジ規格は JIS 10K FF 相当。

注3 質量はモータ不含。

*1 Foundation Dimensions may vary in accordance to Motor Size.

*2 Flange Standard Is JIS 10K FF EQ.

*3 Motor Mass is not included.